



Entry level, light duty L-Bar sealer

- Micro Knife Band Ribbon Seal
 - Motorized Discharge Conveyor
 - Stainless Steel Compensator
 - Seal and Magnet Timer
 - Dual Magnet Hold Down
 - Stainless Steel Film Clamps
 - Pin Wheel Hole Punch
 - Discharge Conveyor Timer
 - Locking Casters
 - Powder Coated Frame
 - Transition Rollers on Discharge
- Conveyor
 - Adjustable Loading Tray
 - 8-10 PPM
 - Recommended Film: POF (PVC not recommended)

More Information:

Our SS-1519LMC L- Bar Sealer (15"W x 19"L Seal Area) is an entry-level, light duty L-Bar Sealer with Micro Knife Seal Technology allowing you to get years of use with minimal repairs. This machine is capable of operating at speeds of 8-10 PPM.

The SS-1519LMC is a proven workhorse with thousands of machines in the field successfully running since 1993. Our 20 plus years of experience as the industry leader in manufacturing semi and fully automatic L-Bar Sealers will give you the peace of mind knowing you have purchased the best machine available on the market today!

Our mission is to provide our customers with the latest technology and a user friendly machine that is efficient and easy to maintain. The SS-series brand will give you the lowest total cost of ownership available in the market. We partner with a nationwide network of highly trained packaging distributors in order to better serve our customers. This partnership provides a support structure to ensure a smooth startup, reliable local service and a long term return on your machinery investment.

Options Available for magnet hold down only (SS-1519LM) or w/o magnet hold and w/o discharge conveyor (SS-1519L)

Specifications:

POWER	110V / 1PHASE / 10AMPS
SEAL DIMENSIONS	15" X 19" (W X L)
MAX FILM WIDTH	20"
NET WEIGHT (LBS)	331
MACHINE DIMENSIONS	53" X 24" X 45"
CRATED DIMENSIONS	42" X 26" X 48"

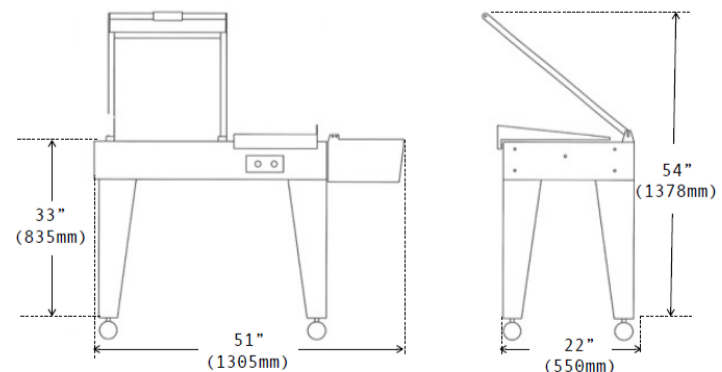

ENTRY-LEVEL SEMI-AUTOMATIC L-BAR SEALER

Model: SS-1519LMC

Compensator Assembly

Keeps sealing temperature from overheating

Stainless Steel Clamps

Pinwheel Hole Punch

Micro Knife Sealing

The Micro Knife Sealing Technology is the most advanced seal system available on a semi-automatic L-Sealer. This PTFE-coated sealing blade is guaranteed not to break for 1 full year or we will replace at no cost. PTFE coating allows the film to seal with minimal smoke or residue and produces straight seals with no pinholes. It is simply the best seal system on the market today.



Conveyor Timer

On/Off Switch

Seal / Magnet Timer

20" Film Cradle w/ Roll Brake

OPTIONS



SS-1519L
 No Magnet Hold
 No Power Discharge Conveyor



SS-1519LM
 Magnet Hold Down
 No Power Discharge



SS-1519LMC
 Combo Machine w/
 Shrink Tunnel